

## RECOMMENDED WASHERS & FASTENERS:

See the detailed SunSky Installation Guide for complete information about panel fastening requirements.

**Metal structures:** Self-Drilling Tapping Screw

**Wood structures:** Tapping Screw

**Side Stitching:** Sharp Point Self-Tapping Screw

**Washer:** Palram metal washer with EPDM gasket (see figures 15a, 15b, and 15c; 15c required for FBC-approved installations)

**Grommet:** Expanding rubber fastener (see fig. 15d & 16b; required for FBC-approved installations)

### Palram Metal Washers w/Concave EPDM Gasket



3/4" (19 mm)  
Washer/gasket  
Figure 15a

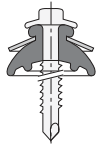

1" (25 mm)  
Washer/gasket  
Figure 15b

### Metal Washer w/EPDM Gasket



#12-14 x 1-1/4" HWH w/1-1/8"  
Oversize Bonded Washer  
(pre-drilling w/oversize holes required)  
Figure 15c



### Grommet Fastener

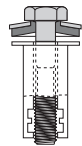

1/4" x 1" Grommet  
(pre-drilling required)  
Figure 15d

### Stitch Screw

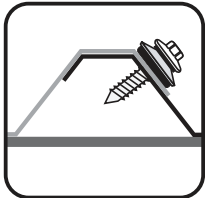

Figure 16a

### Grommet

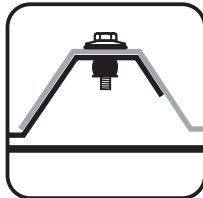

Figure 16b

## SUGGESTED FASTENER TYPES AND PLACEMENT

	SunSky 9"	SunSky 12"
<b>Fastening at crown</b>	1/4" x 2" with 3/4" washer	1/4" x 2-1/2" with 1" washer
<b>Fastening at valley</b>	1/4" x 1-1/2" with 1" washer	1/4" x 1-1/2" with 1" washer



Premium Corrugated Polycarbonate Panels

# Polycarbonate RIDGE CAP Installation Overview

Authorized Palram Dealer



### PALRAM AMERICAS

9735 Commerce Circle, Kutztown, PA 19530  
Phone: 800-999-9459 • Fax: 610-285-9928  
Web Site: [www.PalramAmericas.com](http://www.PalramAmericas.com)

Inasmuch as Palram Americas has no control over the use to which others may put the product, it does not guarantee that the same results as those described herein will be obtained. Each user of the product should make his own tests to determine the product's suitability for his own particular use including the suitability of environmental conditions for the product. Statements concerning possible or suggested uses of the products described herein are not to be construed as constituting a license under any Palram Americas patent covering such use or as recommendations for use of such products in the infringement of any patent. Palram Americas or its distributors cannot be held responsible for any losses incurred through incorrect installation of the product. In accordance with our company policy of continual product development you are advised to check with your local Palram Americas supplier to ensure that you have obtained the most up to date information.

Palram Americas reserves the right to change product specifications and/or information contained in this brochure without notice.

Form # 509 Revised 04.04.2011 SCS  
(Formerly Form #508)

## IMPORTANT!

This installation overview is for SunSky Polycarbonate Ridge Caps only. For complete installation details for SunSky panels, see Form #505, titled SunSky Installation Guide, available at [www.PalramAmericas.com](http://www.PalramAmericas.com), or by contacting Palram Americas by phone at (800) 999-9459.

**The following installation points are required in order to ensure proper installation of the SunSky Ridge Cap:**

Figure 1

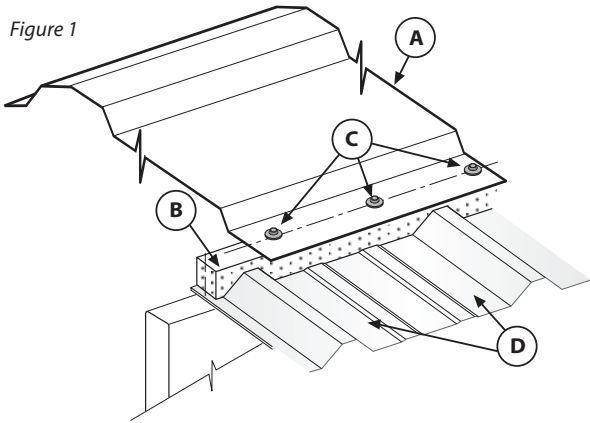

1. SunSky ridge caps (A) should be installed on XPE (foamed polyethylene) shaped top end-closures (B) as shown. Foam closures should be set no less than 1/2" from the top of the panel.
2. Fasteners (C) should be installed at the valley of the panel's (D) corrugation pattern, for each corrugation interval. This should be done on both sides of the ridge cap.
3. Fasteners should be installed at least one inch from the edge of the ridge cap. Installing a fastener too close to the edge may cause the material to eventually tear.
4. ALL fastener sites in the ridge cap must be pre-drilled to a diameter at least 1/16" larger than the fastener diameter to account for thermal movement.
5. Only Palram recommended fasteners may be used to install SunSky ridge caps. Palram recommends fasteners using an EPDM or neoprene washer at least 3/4" (19mm) in diameter. Fasteners should be installed so that the washer is pressed snugly against the ridge cap, but not to the point where the washer is deformed (see Figure 2). Overtightening the fastener will prevent the

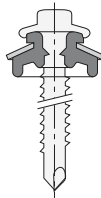
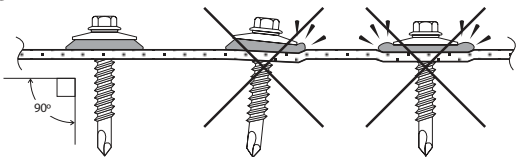

Figure 2



ridge cap from properly expanding and contracting with temperature changes.

6. Be sure to work in one direction. Do not begin fastening at both ends and working towards the center.
7. Fasteners should be installed so that they are securely fastened to the underlying structure as shown in Figure 3. The ridge cap should be directly connected to the purlin or horizontal support member.
8. It is suggested that ridge caps are supported from below using either blocks or brackets at intervals of 60" (30" on the 1.0mm Ridge Cap.) The nature of these supports is at the discretion of the installer, but the following observations must be made:

Figure 3

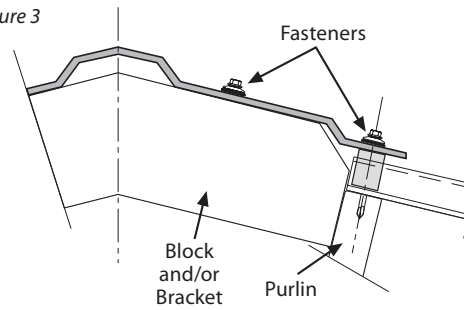

- a. Blocks and/or brackets should approximate the geometry of the ridge cap in order to insure that they sit properly.
  - b. Blocks and brackets should be fastened directly to the structure of the building.
  - c. The Ridge Cap should be connected to the blocks or brackets through a pre-drilled, oversized penetration. Palram fasteners are recommended and installation should account for thermal expansion as described above.
9. Ridge cap sections should overlap by at least 4 inches (Figure 4). It is recommended that this overlap be sealed with 1/2" Butyl tape. All ridge cap overlaps require a ridge cap block for through fastening (Figure 5).

Refer to Palram Americas or its distributor for other approved sealing or bonding materials should they be required. Unapproved sealing or bonding material may be incompatible, damage the panels, cause failure and void warranty.

**Ridge Cap Overlap Illustration**

(Figure 4)

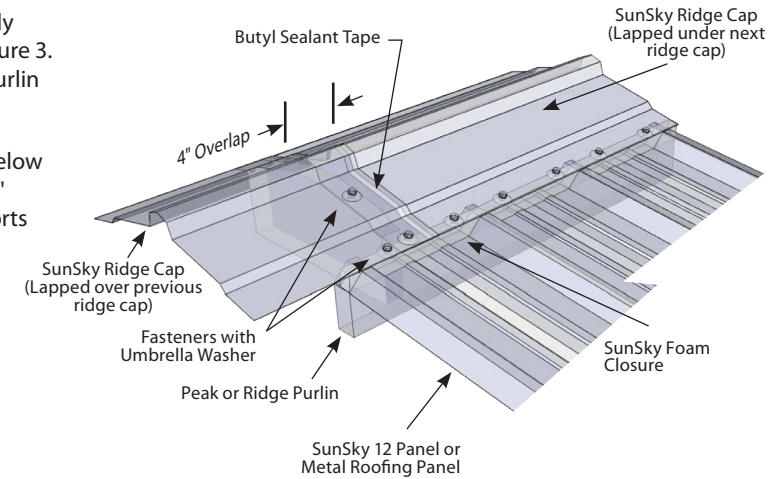

**Ridge Cap Block Illustration**

(Figure 5)

